



XPHPK



XPHTK

本體		內襯
材質	硬度	材質
SUJ2	HRC45	銅合金

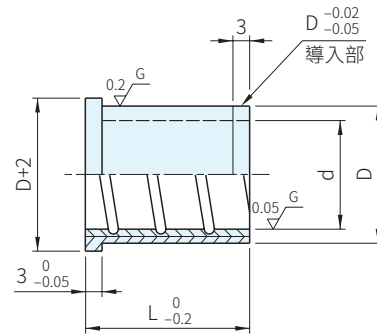
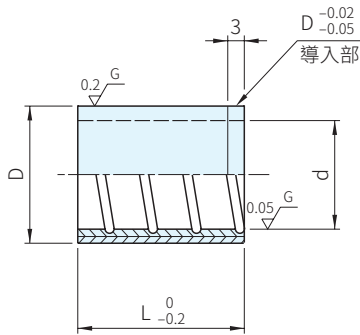

TYPE	品號		L						D	庫存		
	d		10	13	16	20				XPHPK	XPHTK	
XPHPK XPHTK	10	-0.003 -0.005	10	13	16	20			16	+0.002 0	△	△
	13			13	16	20	25		20		△	△
	16				16	20	25	30	24		△	△
	20					20	25	30	28		△	△

**WA) 注意**

- XPHPK, XPHTK和XHSG, XHSM, XHSP, XHSQ導柱配合使用
- 適當的給油, 導柱導套壽命更佳
- 高速導柱、導套、滾珠套專用之有機鉬強力潤滑劑請參考 S-00668
- 以輕滑配或厭氧膠(LOC680, LOC638)黏著固定

訂貨：  ×  交期： 天

XPHPK10 × 10